



### Features

- 5.7" TFT LCD with resistive touchscreen
- DM&P Vortex86DX 1GHz onboard
- 256/512MB DDR2 system memory onboard
- Compact Flash Type I/II / Micro SD Slot
- Mini-PCI socket (Wi-Fi Optional)
- Fanless and low power consumption
- Metal chassis with compact design

### Introduction

PDX-057T is an ultra compact platform for the present demanding embedded and productive applications. It has new Vortex86DX SoC CPU which consumes only minimum power requirement when running at 1GHz, and DDR2 memory provides faster data transfer rate. By using 5.7" TFT LCD, PDX-057T becomes the perfect choice for a limited budget. In addition, the integrated 10/100M Ethernet port supplies the communication capability which makes PDX-057T can be more widely used when running with DOS, Linux, Windows CE, and Windows XP environment to become the perfect solution for system integration.

### Specifications

<b>CPU</b>	DM&P SoC CPU Vortex86DX-1GHz
<b>Cache</b>	L1:16KB I-Cache, 16KB D-Cache L2: 128KB Cache
<b>BIOS</b>	AMI BIOS
<b>Memory</b>	256/512MB DDR2 onboard
<b>Watchdog Timer</b>	Software programmable from 30.5u to 512 seconds x 2 sets
<b>LAN</b>	Integrated 10/100Mbps Ethernet
<b>Audio (Optional)</b>	CM119 Line-Out
<b>Internal Drives</b>	Compact Flash Type I/II slot Micro SD slot
<b>I/O</b>	RS-232/422/485 x 1 USB ports (Ver2.0) x 2
<b>Expansion Slot</b>	Mini-PCI socket x 1

### Mechanical & Environment

<b>Power Requirement</b>	+5V DC +8 ~ +35V DC (Optional)
<b>Power Consumption</b>	+5V @ 1.3A
<b>Operating Temperature</b>	-20 ~ +60 °C (-4 ~ +140 °F)
<b>Storage Temperature</b>	-30 ~ +70 °C (-22 ~ +158 °F)
<b>Dimensions</b>	152 x 112 x 33 mm (5.98 x 4.41 x 1.3 inches)
<b>Weight</b>	374g
<b>Certification</b>	CE, FCC, VCCI, Vibration

### LCD Specifications

<b>Display Type</b>	5.7" TFT LCD
<b>Backlight Unit</b>	LED
<b>Display Resolution</b>	640 (W) x 480 (H)
<b>Brightness (cd/m<sup>2</sup>)</b>	500 cd/m <sup>2</sup>
<b>Contrast Ratio</b>	300:1
<b>Display Color</b>	262,144
<b>Dot Pitch (mm)</b>	0.06 x 0.18
<b>Viewing Angle</b>	Vertical 100°, Horizontal 140°
<b>Backlight Lifetime</b>	25,000 hrs

### Touchscreen

<b>Type</b>	Analog Resistive
<b>Resolution</b>	Continuous
<b>Transmittance</b>	80%
<b>Controller</b>	USB interface
<b>Software Driver</b>	DOS/Linux/WinCE/WinXP
<b>Durability</b>	1 million

**Dimensions**

Unit: mm

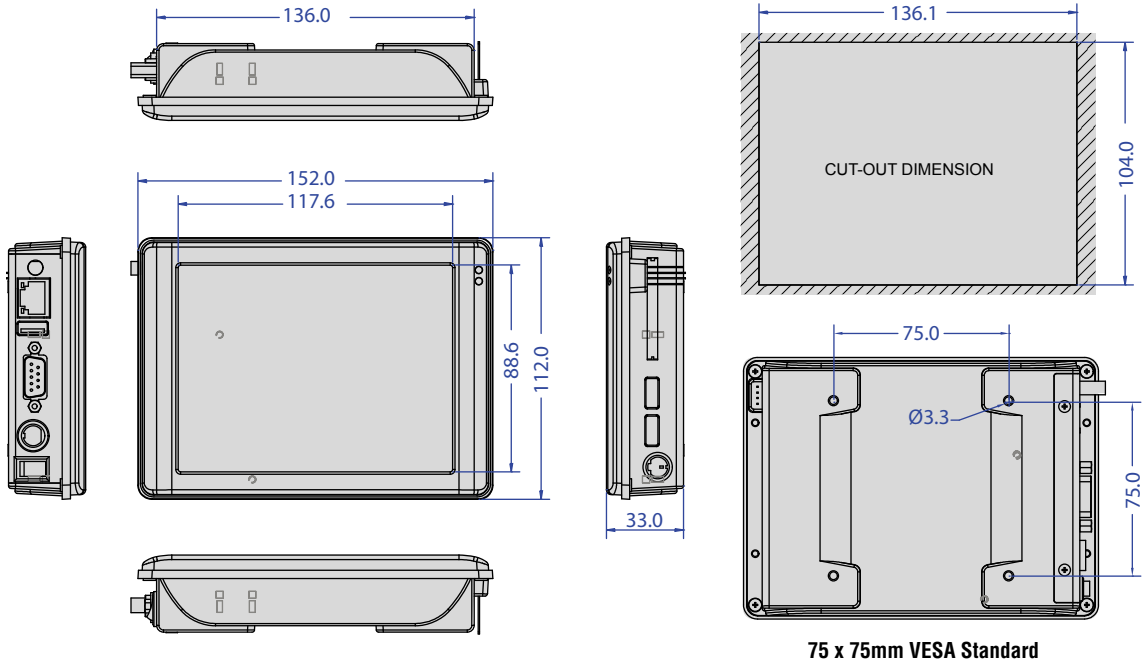

1

µProcessor Module

2

Mity/Tiny CPU Module

3

PC/104 CPU Module

4

Half-Size CPU Module

5

3.5" CPU Module

6

Peripheral Module

7

Display Product Series

8

Accessories & Technical Information

**Side View**

PDX-057T-D8A

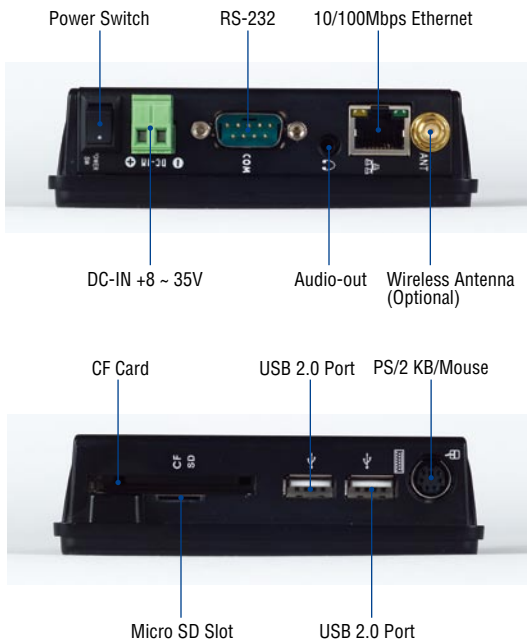

PDX-057T-D5A

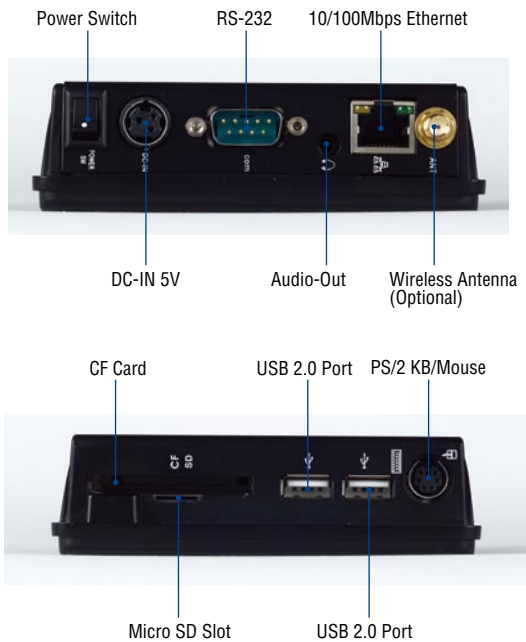

**Ordering Information**

- **PDX-057T-D5A** 5.7" Vortex86DX Panel PC w/256MB DDR2 /2USB/Line-Out/LAN/1COM/CF/MicroSD/15W Power Adapter
- **PDX-057T-D8A** 5.7" Vortex86DX Panel PC w/256MB DDR2 /2USB/Line-Out/LAN/1COM/CF/MicroSD